

**ENGLISH:** ASSEMBLY DRAWINGS SHOULD BE REVIEWED BEFORE PROCEEDING WITH CONSTRUCTION. A NUMBER IDENTIFIES EACH PLASTIC PART FOR YOUR CONVENIENCE. PAINT SMALL PARTS ON RUNNER BEFORE REMOVING. ALLOW PAINT TO DRY THOROUGHLY BEFORE CONTINUING ASSEMBLY OF KIT. SCRAPE CHROME OR PAINT AT AREA TO BE GLUED. WASH PLASTIC IN MILD DETERGENT SOLUTION. RINSE AND LET AIR DRY FOR BETTER PAINT AND DECAL ADHESION.

**DEUTSCH:** VOR DEM ZUSAMMENBAU DIE BAUANLEITUNG GUT DURCHLESEN. JEDES TEIL IST NUMERIERT. KLEINE TEILE ANSTREICHEN BEVOR SIE VOM RAHMEN ENTFERNT WERDEN. FARBEN GUT TROCKNEN. ERST DANN DEN ZUSAMMENBAU FORTSETZEN. CHROM UND FARBE AN DEN KLEBEFLÄCHEN ENTFERNEN. PLASTIKTEILE IN EINER MILDEN WASCHMITTELLÖSUNG REINIGEN UND AN DER LUFT TROCKNEN, DAMIT FARBE U. ABZIEHBILDER BESSER HAFTEN.

**FRANCAIS:** EXAMINER LES SCHEMAS D'ASSEMBLAGE AVANT DE COMMENCER LA CONSTRUCTION. UN NUMERO IDENTIFIE CHAQUE PIECE DE PLASTIQUE POUR PLUS DE FACILITE. PEINDRE LES PETITES PEICES SUR LE SUPPORT AVANT DE LES ENLEVER. LAISSER LA PEINTURE SECHER COMPLETEMENT AVANT DE CONTINUER L'ASSEMBLAGE DU KIT. GRATTER LE CHROME OU LA PEINTURE SUR LES SURFACE A COLLER. LAVER LE PLASTIQUE DANS UNE SOLUTION DE DETERGENT LEGERE, RINCER ET LAISSER SECHER A L'AIR POUR UNE MEILLEURE ADHERENCE DE LA PEINTURE ET DES DECALS.

**NEDERLANDS:** BESTUDER DE MONTAGE TEKENINGEN. VOORDAT U MET BOUWEN BEGINT. VOOR UW GEMAK, IDENTIFICEERT EEN NUMMER ELK PLASTIC DEEL. VERF KLEINE DEELTJES OP KIBOOM VOORDAT U ZE VERWYDERD. LAAT VERF GRONDIG DROGEN VOORDAT U DE MONTAGE VAN HET MODEL VOORTZET. SCHRAP CHROOM OF VERF VAN HET GEDeelTE DAT GELYMD WORDT. WAS PLASTIC MET EEN ZACHT ZEEP. SPOEL AF. EN LAAT IN LUCHT DROGEN. ZODAT VERF EN DECAL BETER PLAKKEN.

**SVENSKA:** IHOPSÄTTNINGSSKISSEN BÖR GRANSKAS INNAN IGÅNGSÄTTANDE AV BYGGANDET. ETT NUMMER IDENTIFIKERAS VARJE PLASTDEL FÖR DIN EGEN BEKVÄMLIGHET. MALA DE SMA BITARNA DIREKT PÅ FARAN INNAN DE TAS BORT. LÅT FARGEN TORKA GRUNDLIGT INNAN FORTSATT BYGGANDE. SKRAPA AV KROMEN ELLER MALA PÅ DELARNA SOM SKALL KLISTRAS. TVÄTTA PLASTEN I MILD TVÄTTMEDLÖSNING, SKOIJ OCH LUFTTORKA FÖR BÄTTRE FASTANDE AV FARG OCH DEKALER.

**ESPAÑOL:** DIBUJOS DE ENSAMBLAJE DEBEN SER REPASADOS ANTES DE SEGUIR CON LA CONSTRUCCION. UN NUMERO IDENTIFICA CADA PARTE DEL PLASTICO PARA SU CONVENIENCIA. PINTÉ PARTES PEQUENAS DEL KIT ANTES DE QUITARLAS. DEJE SECAR BIEN LA PINTURA ANTES DE SEGUIR EL ENSAMBLAJE. RASPE EL CROMO O LA PINTURA DEL SITIO ANTES DE SER PEGADO. LAVE EL PLASTICO EN UNA SOLUCION SUAVE DETERGENTE, ENJUAGUE, Y DEJE SECAR EN EL AIRE PARA MEJOR ADHESION DE LA PINTURA Y CALCOMANIA.

**ITALIANO:** I DISEGNI DELL'ASSEMBLAGGIO DOVREBBERO ESSERE RICONTROLLATI PRIMA DI INIZIARE IL MONTAGGIO. OGNI PEZZO È IDENTIFICATO DA UN NUMERO PER VOSTRA MAGGIORE COMODITÀ. VERNICIARE LE PARTI PICCOLE SULLA GUIDA DI SCORRIMENTO PRIMA DI TOGLIERLE. LASCIAR ASCIUGARE LA VERNICE PRIMA DI CONTINUARE IL MONTAGGIO. RASCHIAR LA PITTURA O IL CROMO DALLE PARTI CHE DEVONO ESSERE INCOLLATE. LAVARE I PEZZI DI PLASTICA CON UN DETERGENTE NON TROPPO FORTE. SCIACQUARE E LASCIAR ASCIUGARE AFFINCHÉ VERNICE E DECALCOMANIE ADERISCANO MEGLIO.



GLUE  
KLEBEN  
COLLE  
LIJM  
KLISTER  
PEGA  
COLLA



NO GLUE REQUIRED  
NICHT KLEBEN  
LA COLLE N'EST PAS NECESSAIRE  
GEEN LIJM NODIG  
INGET KLISTER BEHOVS  
NO NECESITA PEGA  
NON C'E BISOGNO DI COLLA



DO IT THIS MANY TIMES  
ANZAHL DER ARBEITSGÄNGE  
LE FAIRE CE NOMBRE DE FOIS  
DOE HET ZOVEEL KEER  
GJÖR DET SA MANGA GÅNGER  
FATELO TUTTE QUESTA VOLTE  
HAGALO ESTA CANTIDAD DE VECES



OPTIONAL  
WAHLWEISE  
FACULTATIF  
NAAR KEUZE  
VALFRI  
FACOLTATIVO  
OPCIONAL



SHOWN ASSEMBLED  
ABBILDUNG ZUSAMMENGEBAUTER TEILE  
VU ASSEMBLE  
GEMONTEERD GETOOND  
VISAD IHOPSÄTTNING  
MOSTRADO ARMADO  
ILLUSTRAZIONE DEL PEZZO MONTATO

A

MATT BLACK  
MATT SCHWARZ 8  
NOIR MAT  
MATT ZWART  
MATT ZWART  
NERO SMORTO

B

MATT YELLOW  
MATT GELB 15  
JAUNE MAT  
MAT GEEL  
MATT GEEL  
GIALLO SMORTO

C

MATT SAND  
MATT SAND 16  
SABLE MAT  
MAT ZAND  
MATT ZAND  
SABBIA SMORTO

D

EGGSHELL  
EIERSCHALE 18  
COQUE D'ŒUF  
EIJEGEL  
JÓGGJAL  
GUSCIGLI SMORTO

E

MATT RED  
MATT ROT 36  
ROUGE MAT  
MAT ROOD  
MATT ROOD  
ROSSO SMORTO

F

MATT BRICK RED  
MATT ZIEGELROT 37  
ROUGE FONCE MAT  
MAT DONKER ROOD  
MATT DONKER ROOD  
ROSSO SCURO  
SMORTO

G

MATT BROWN  
MATT BRAUN 85  
MARRON MAT  
MAT BRUN  
MATT BRUN  
MARRONE SMORTO

H

MATT OLIVE BROWN  
MATT OLIVBRAUN 86  
MARRON OLIVE MAT  
MAT OLIVBRUN  
MATT OLIVBRUN  
MARRONE OLIVA  
SMORTO

I

LUMINOUS PAINT  
NACHTLEUCHTFARBE 3802  
PEINTURE PHOSPHORESCENTE  
LICHTGEVEND VERF  
SVALVYSANDE FARG  
VERNICE FOSFORESCENTE

J

GOLD  
GOLD 94  
COULEUR OR  
GULD  
GULD  
ORO

K

MATT WHITE  
MATT WEISS 5  
BLANC MAT  
MAT WIT  
MATT WIT  
BIANCO SMORTO

# 10

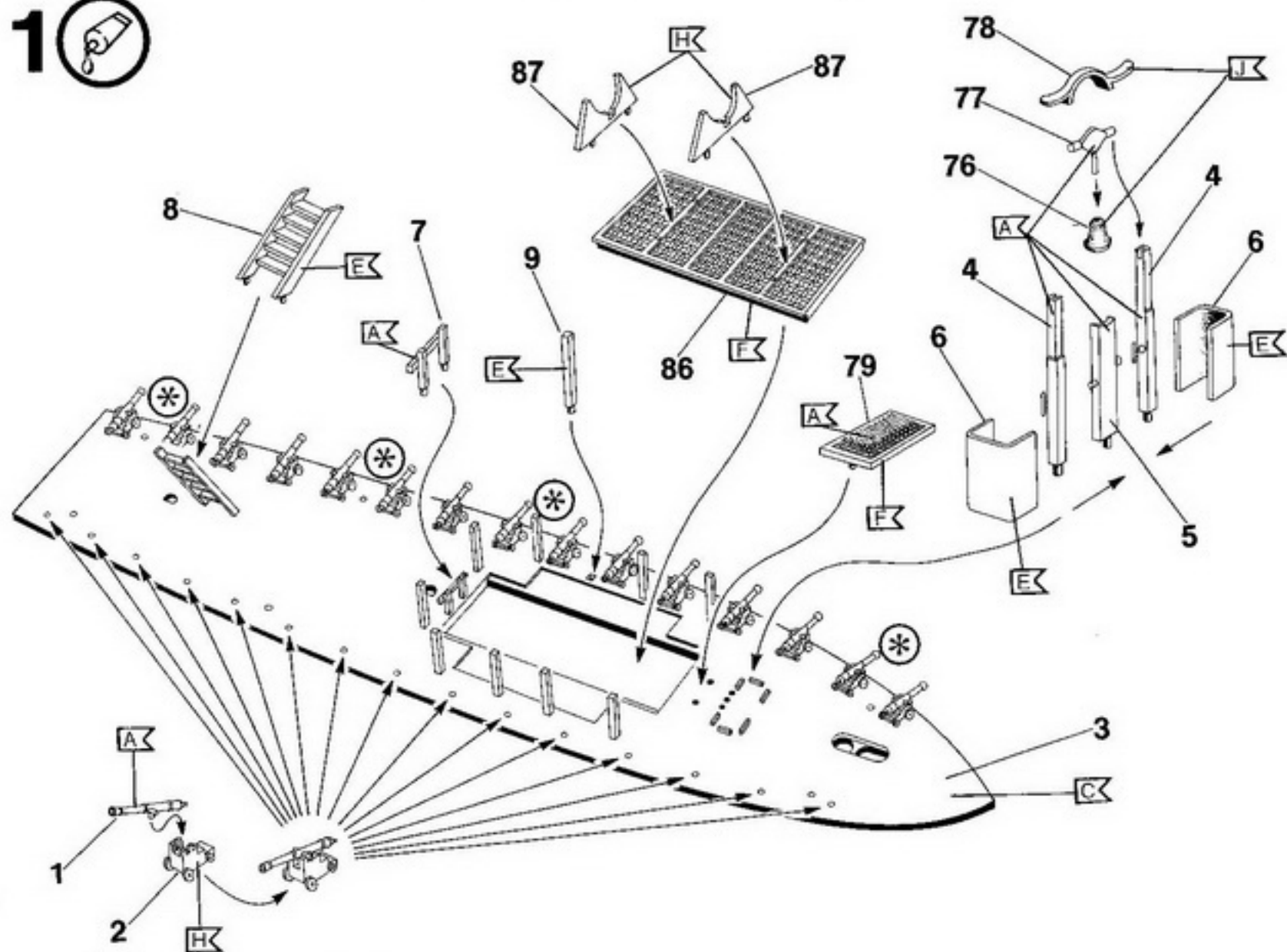
# 20

# 3

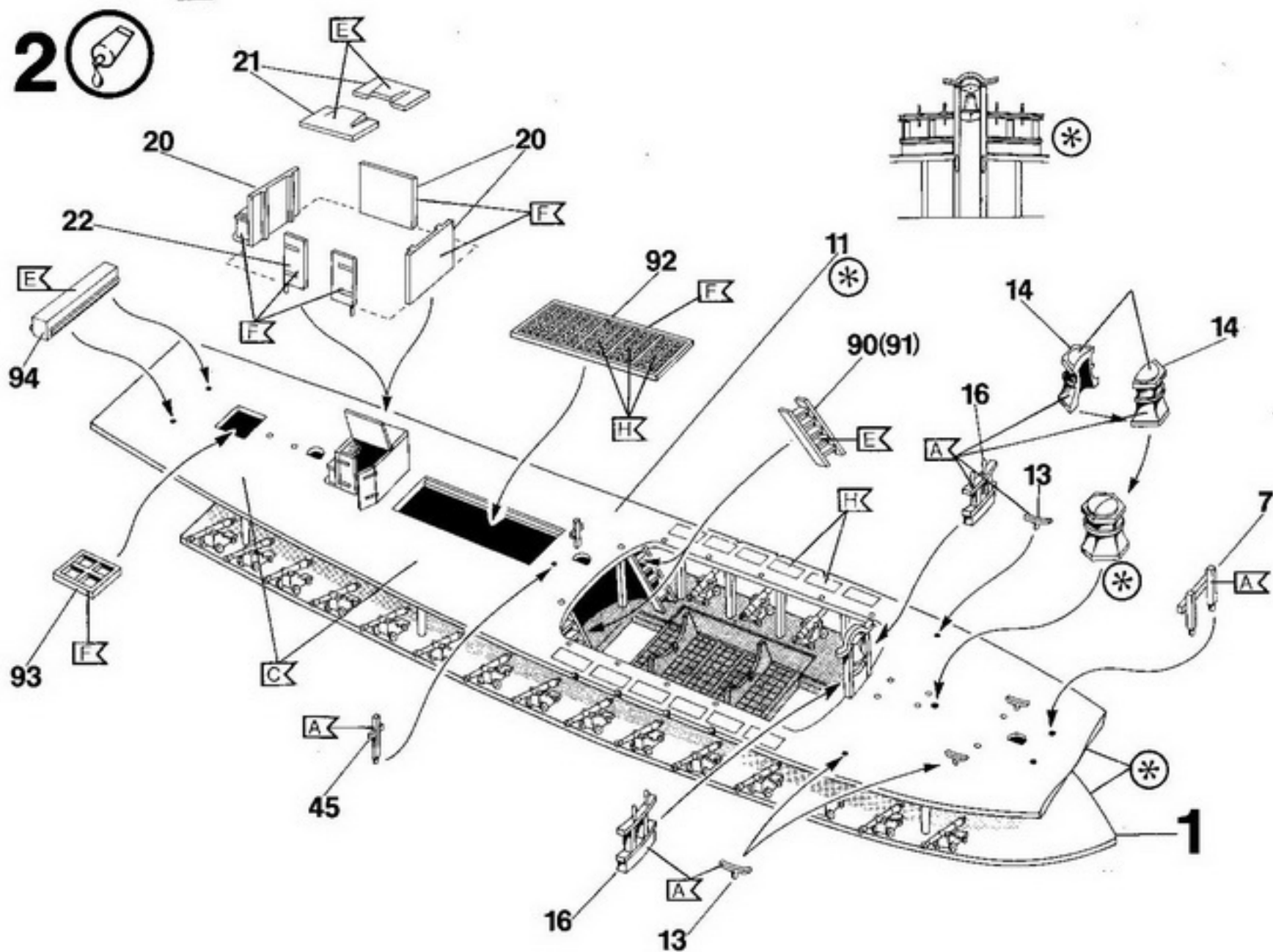

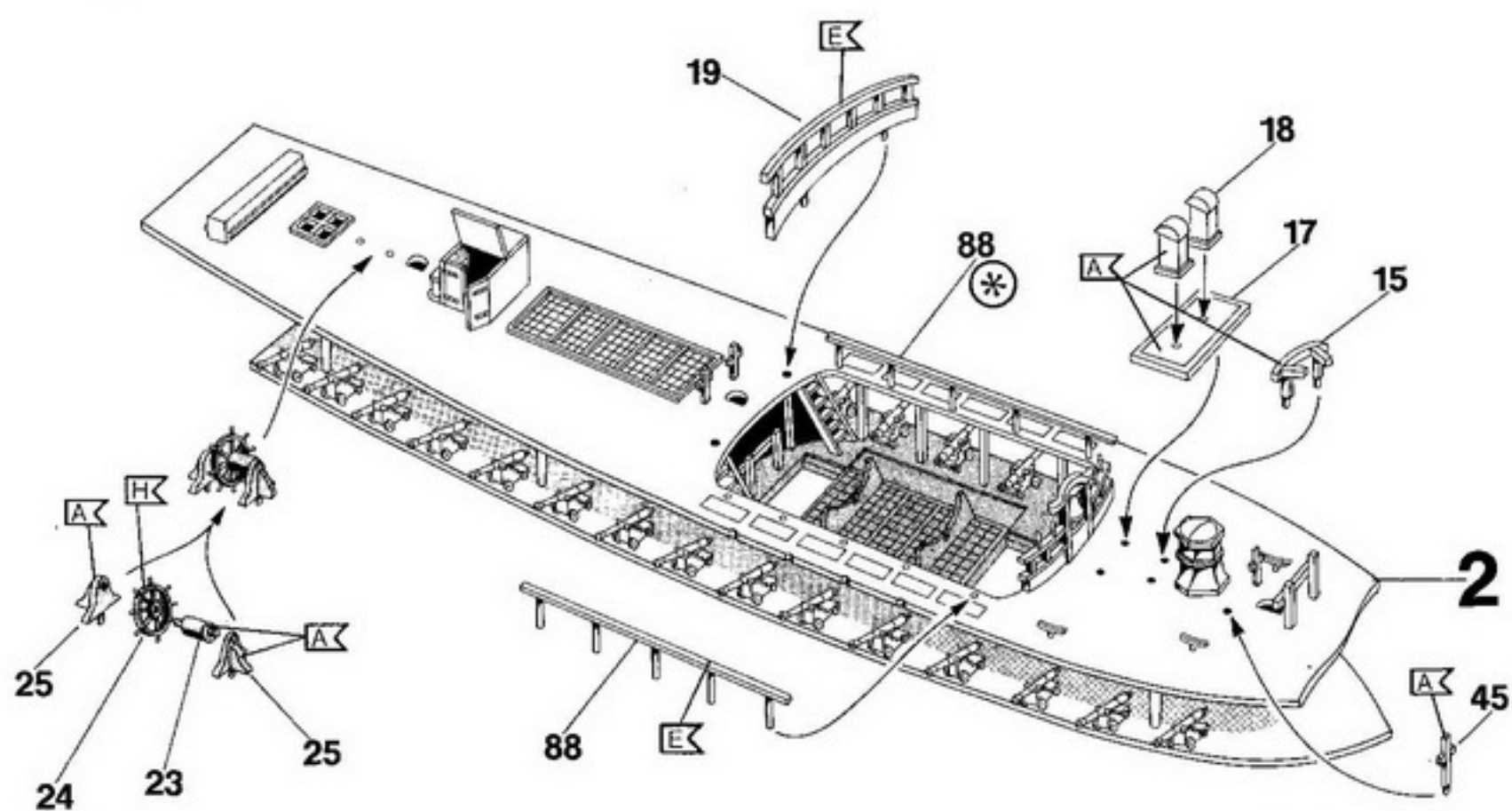

# 4

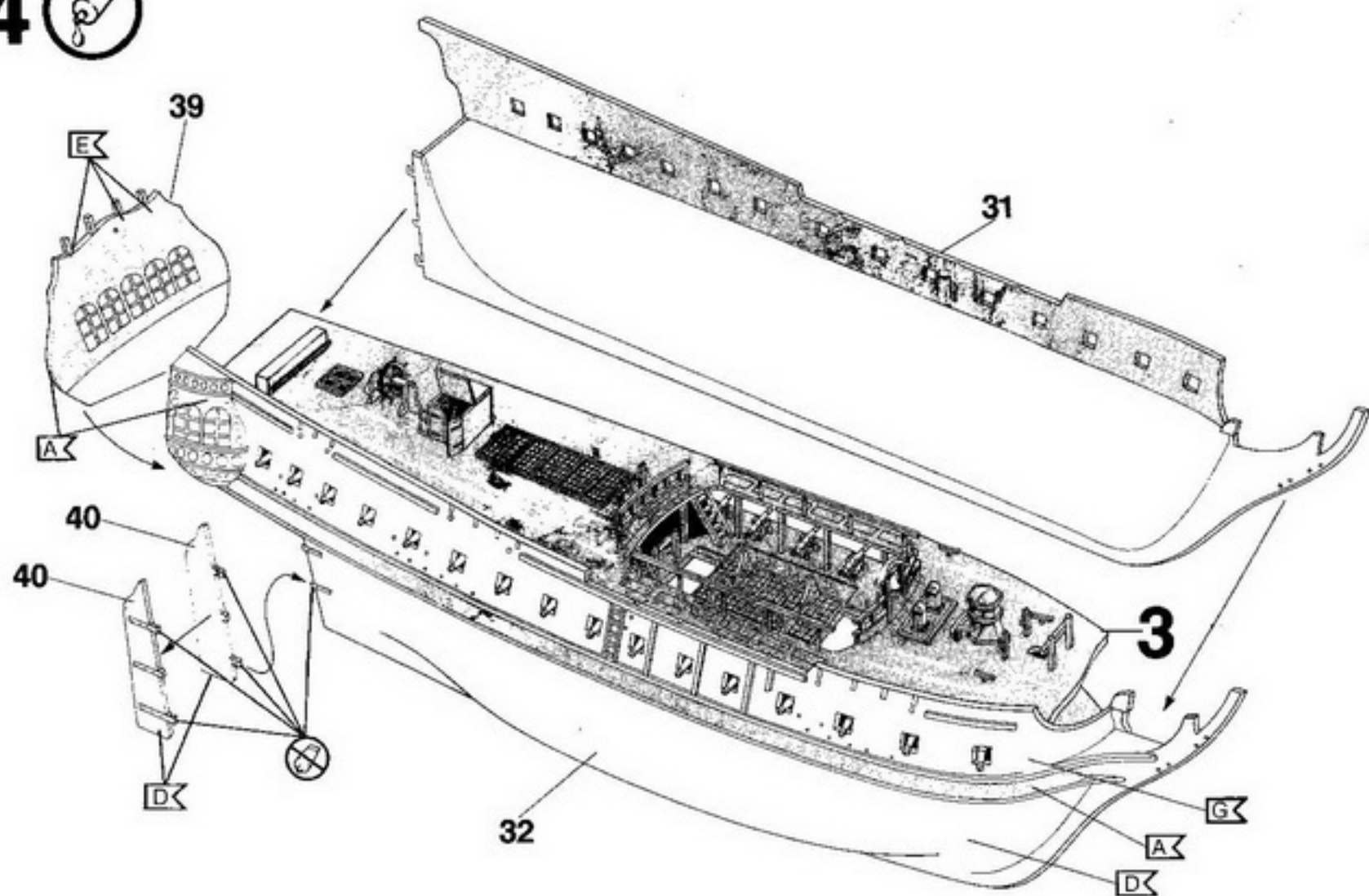



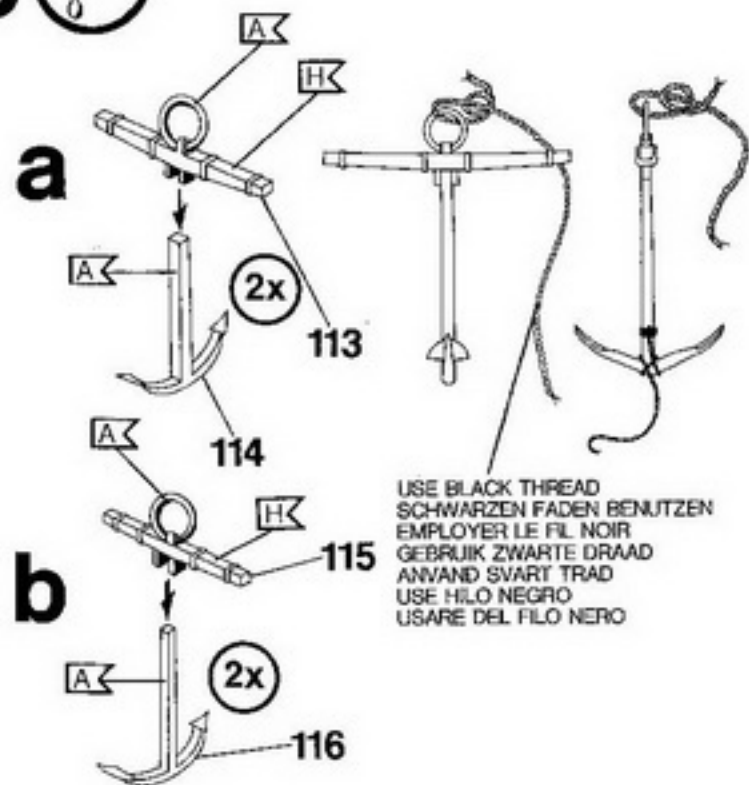
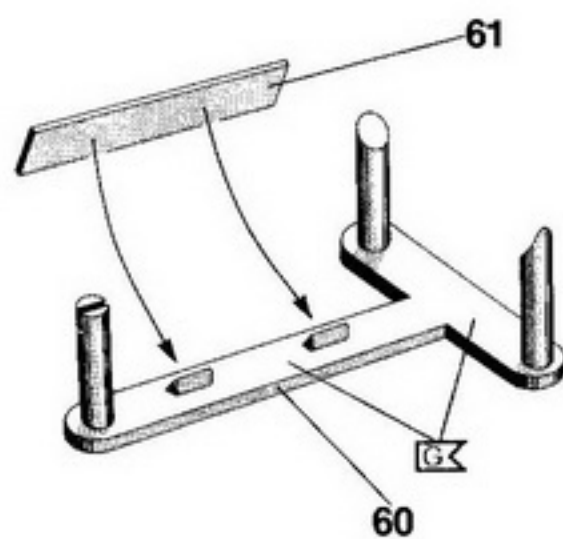
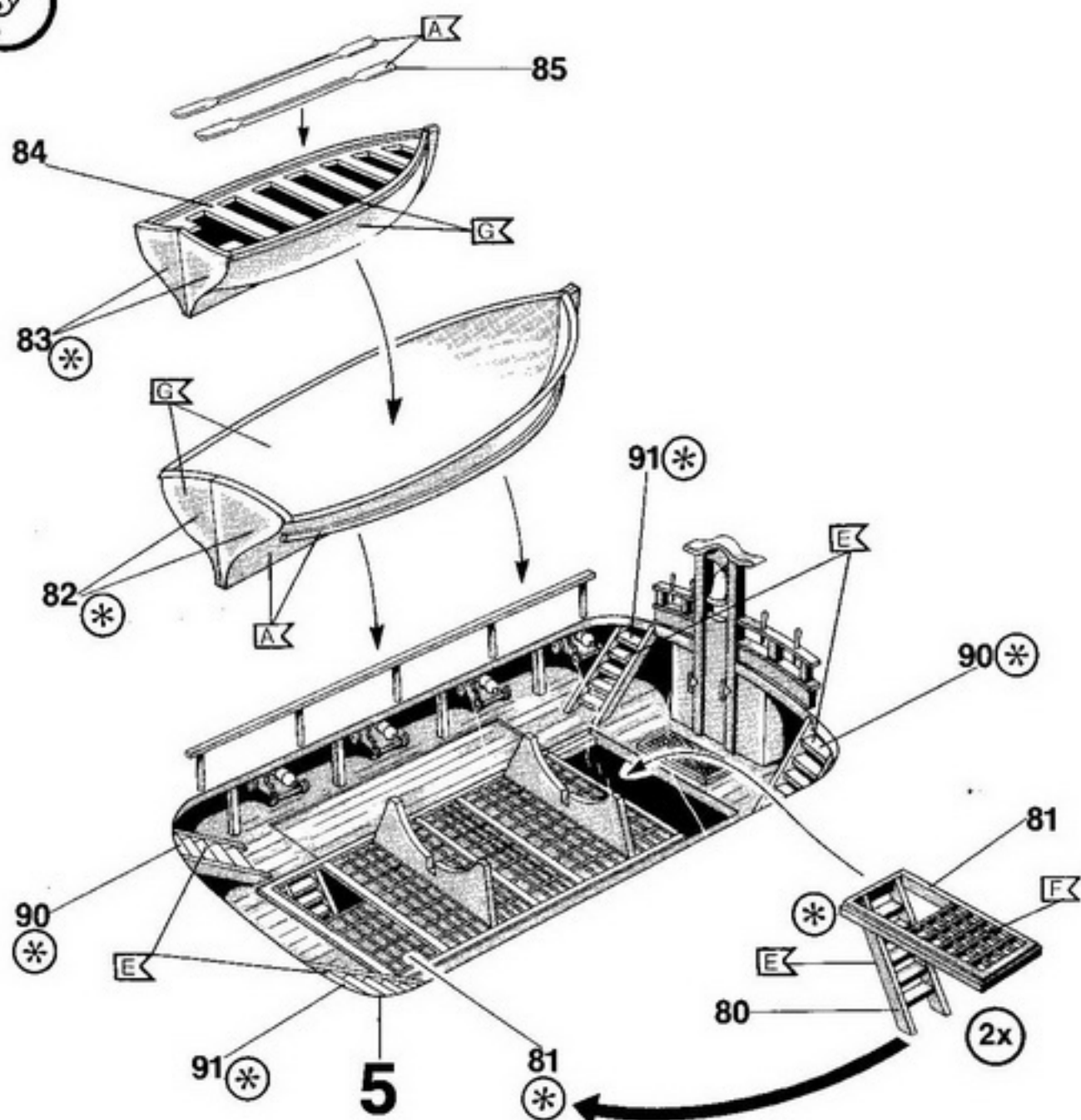

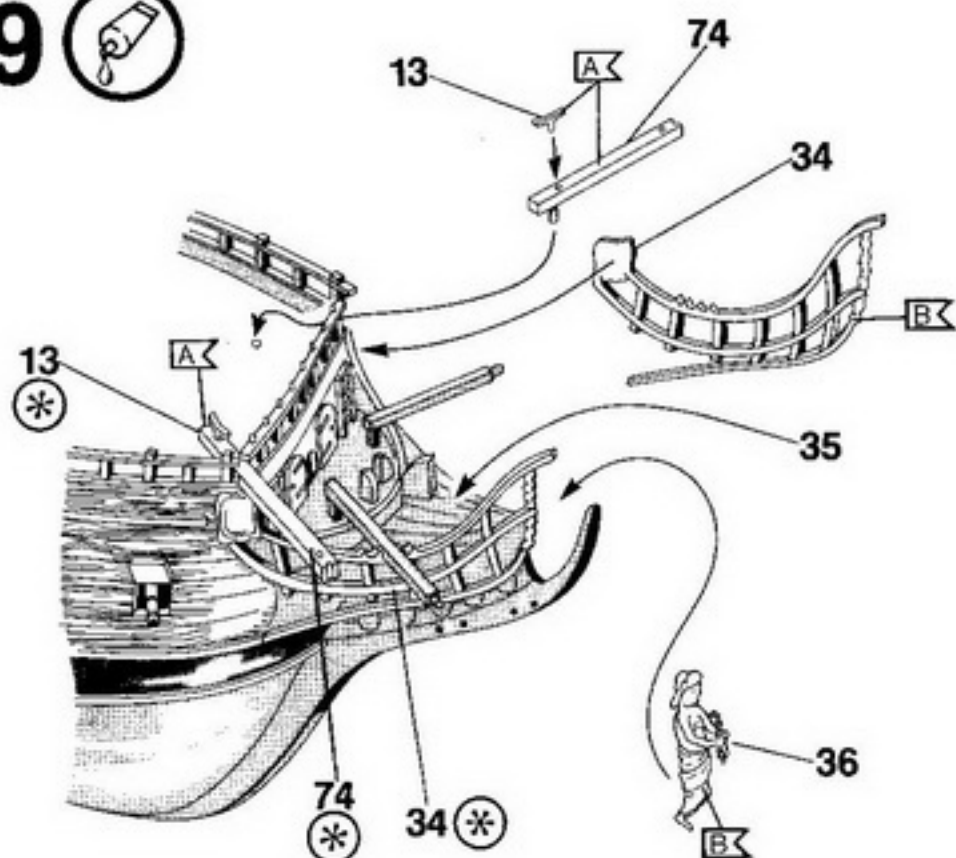

6 7 8 

# 9

# 10



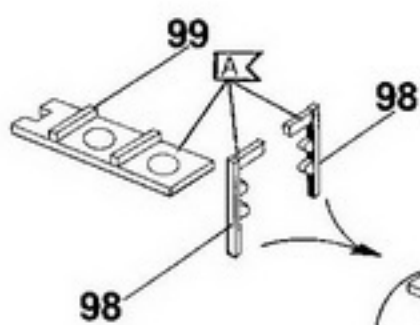
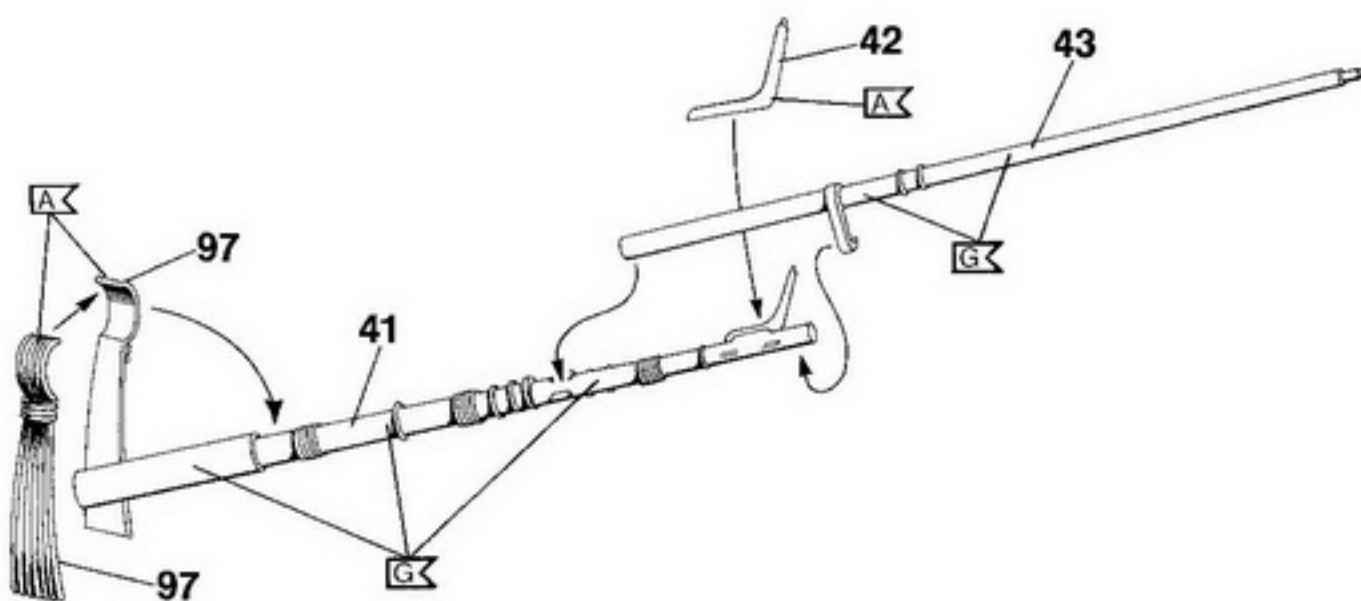

# 11

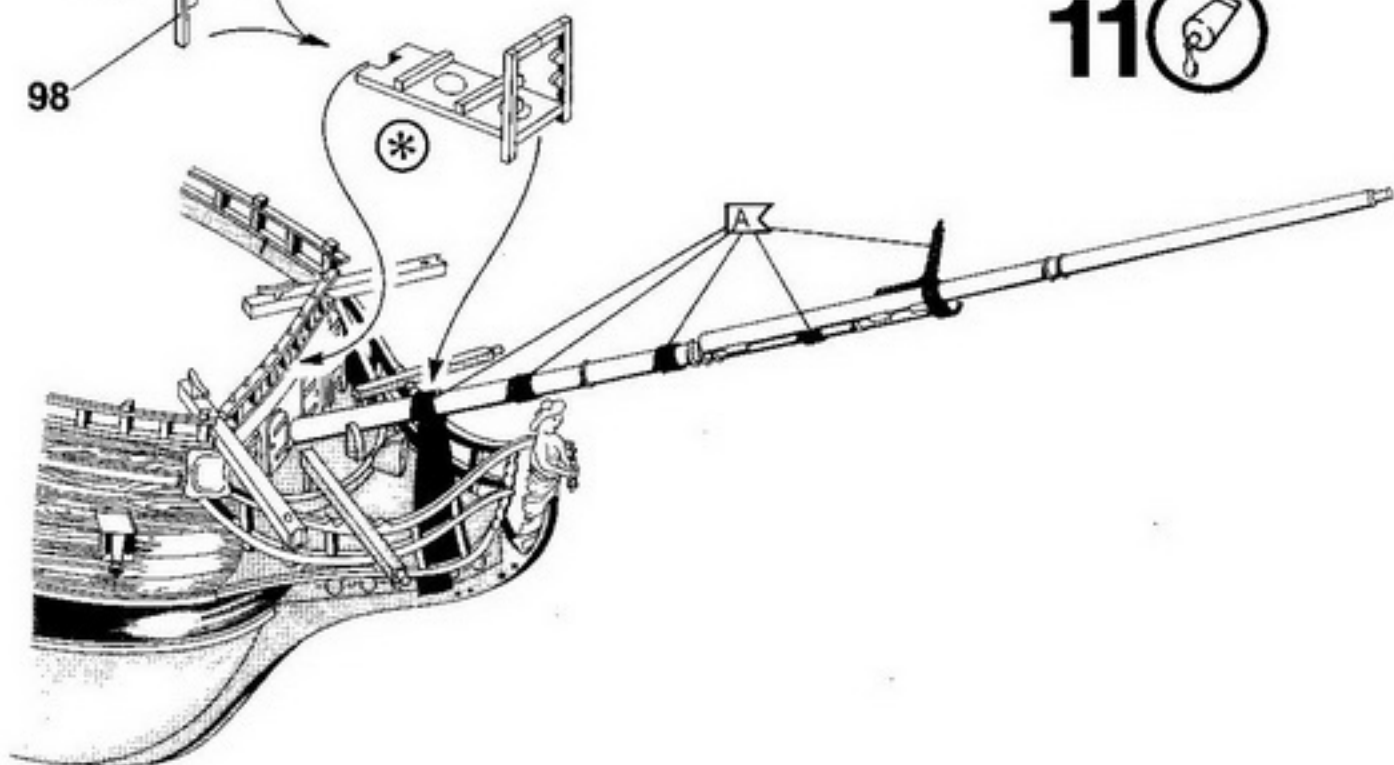



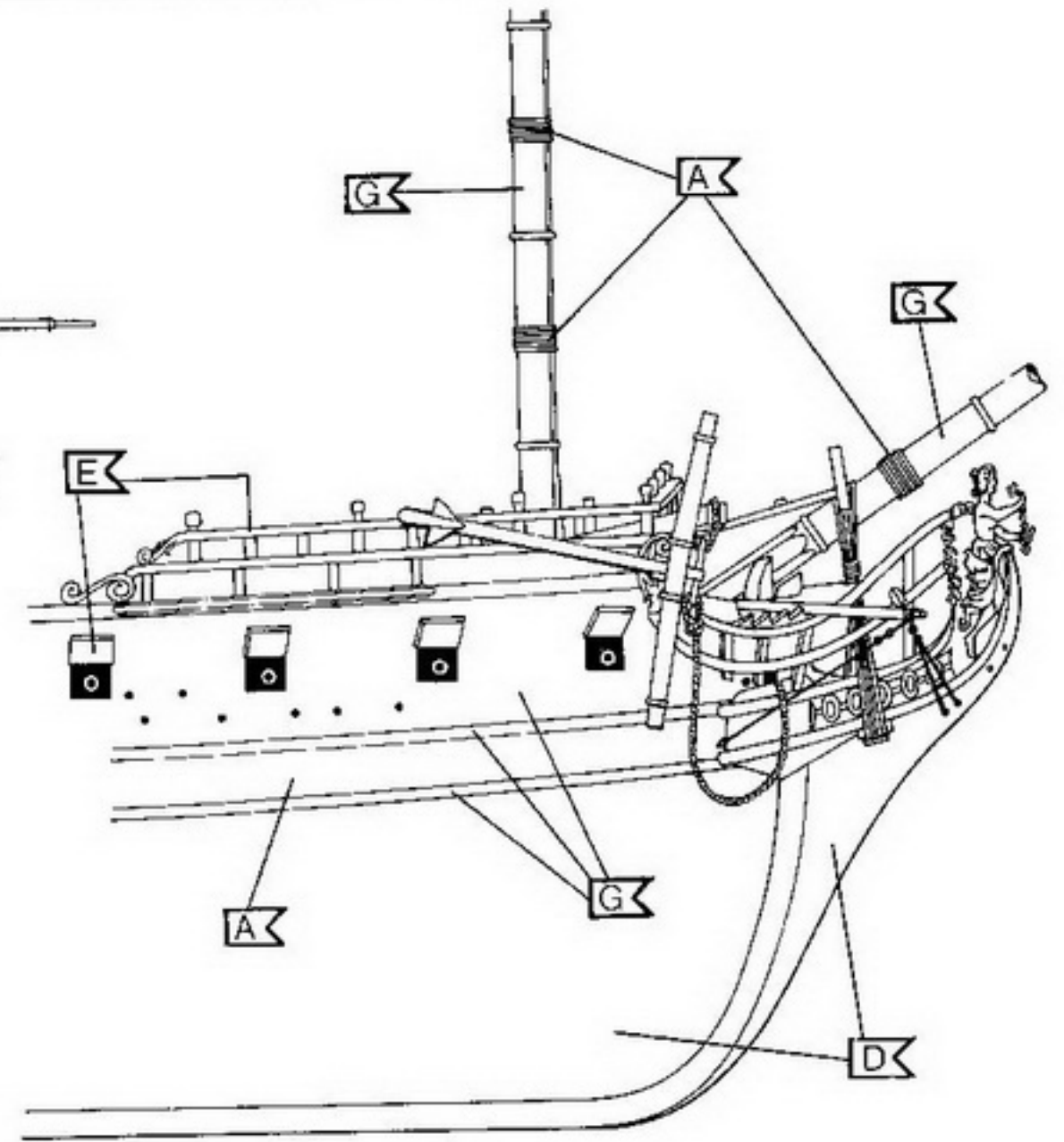
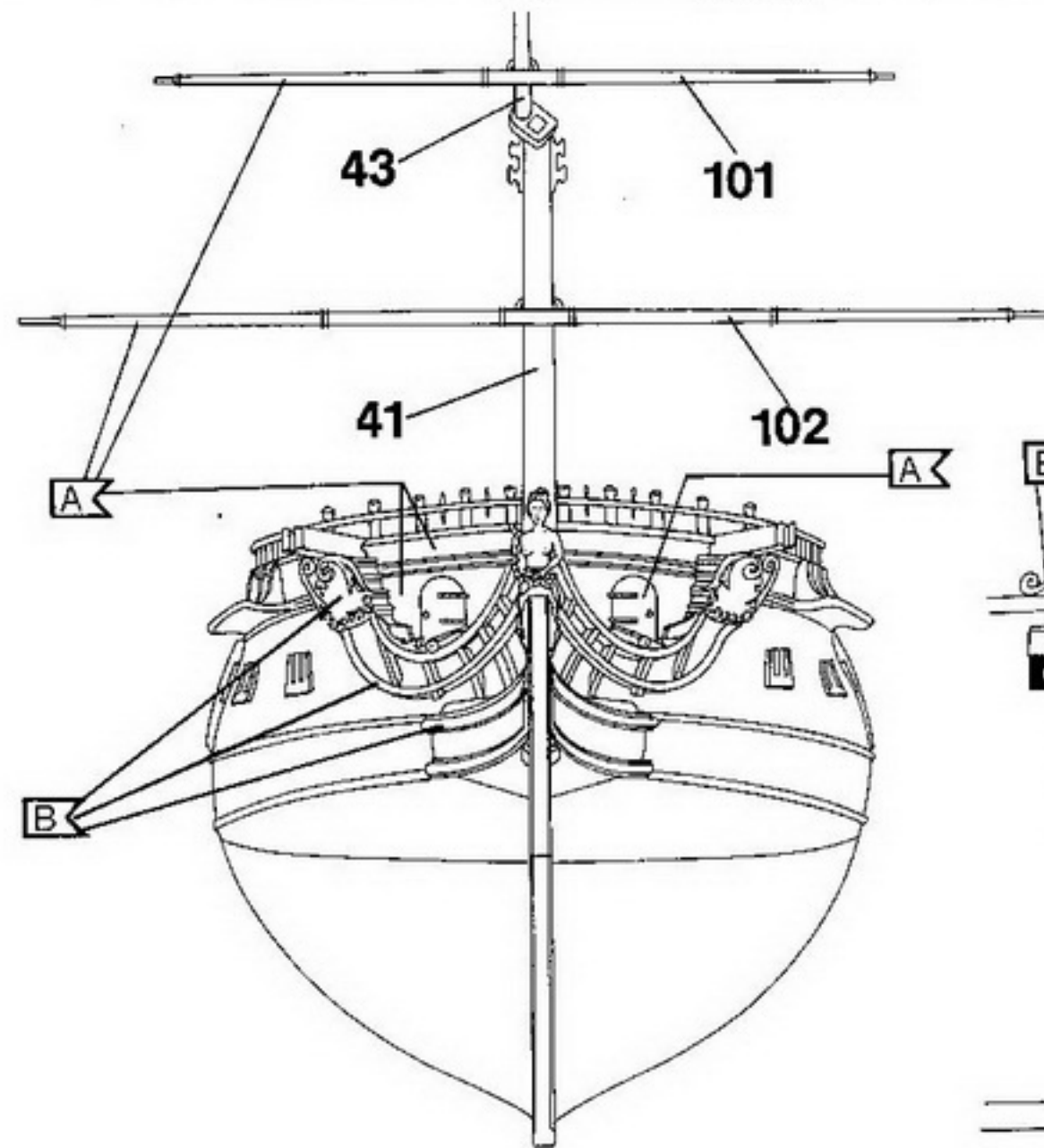
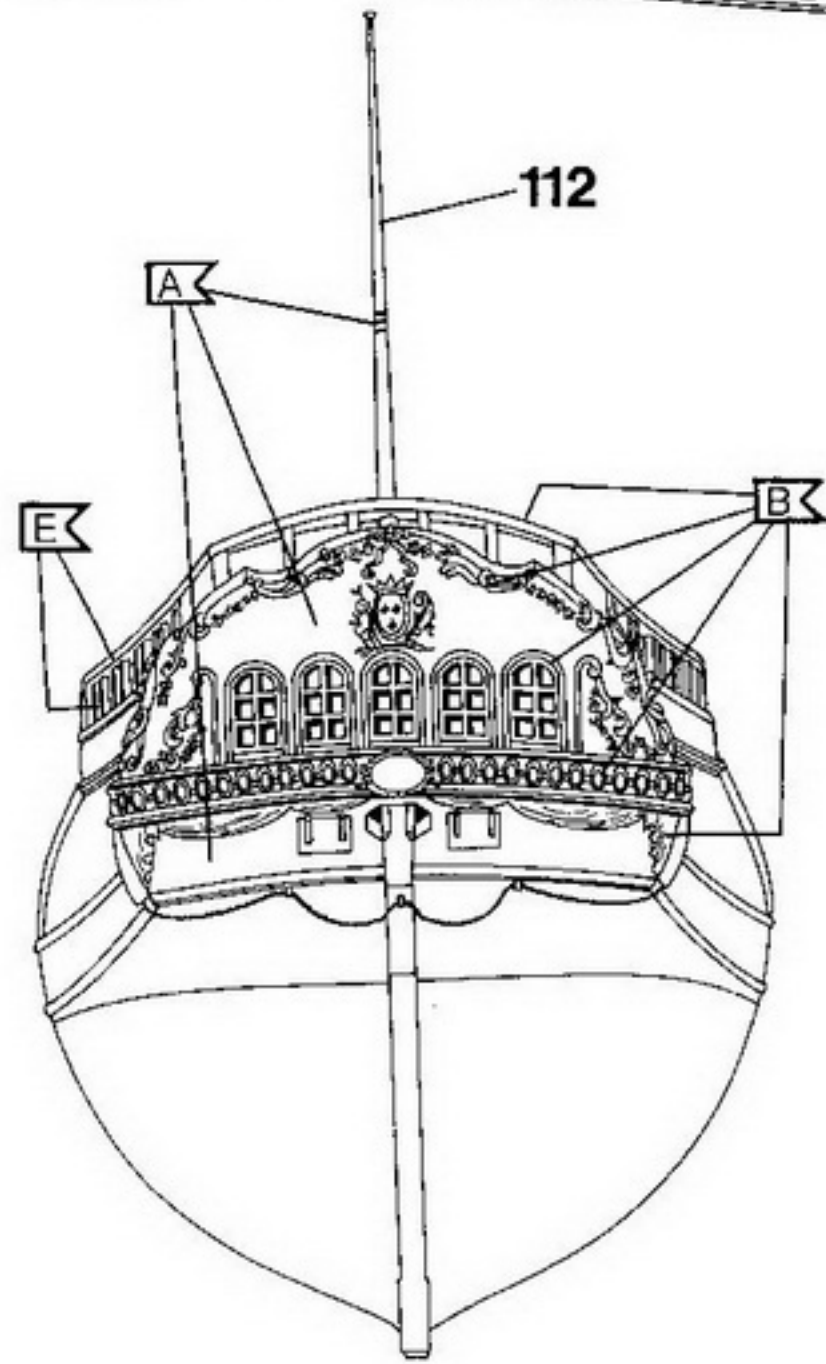
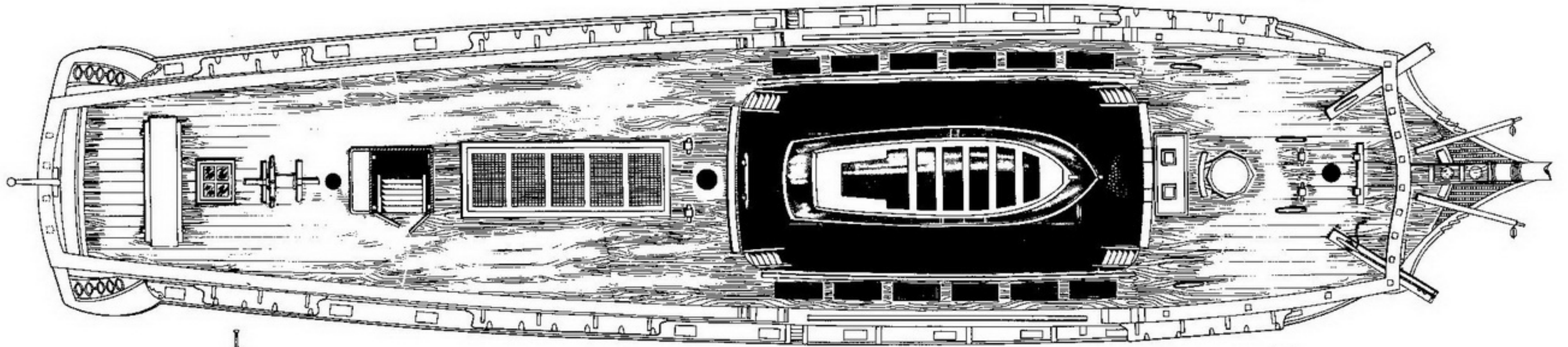

# 12

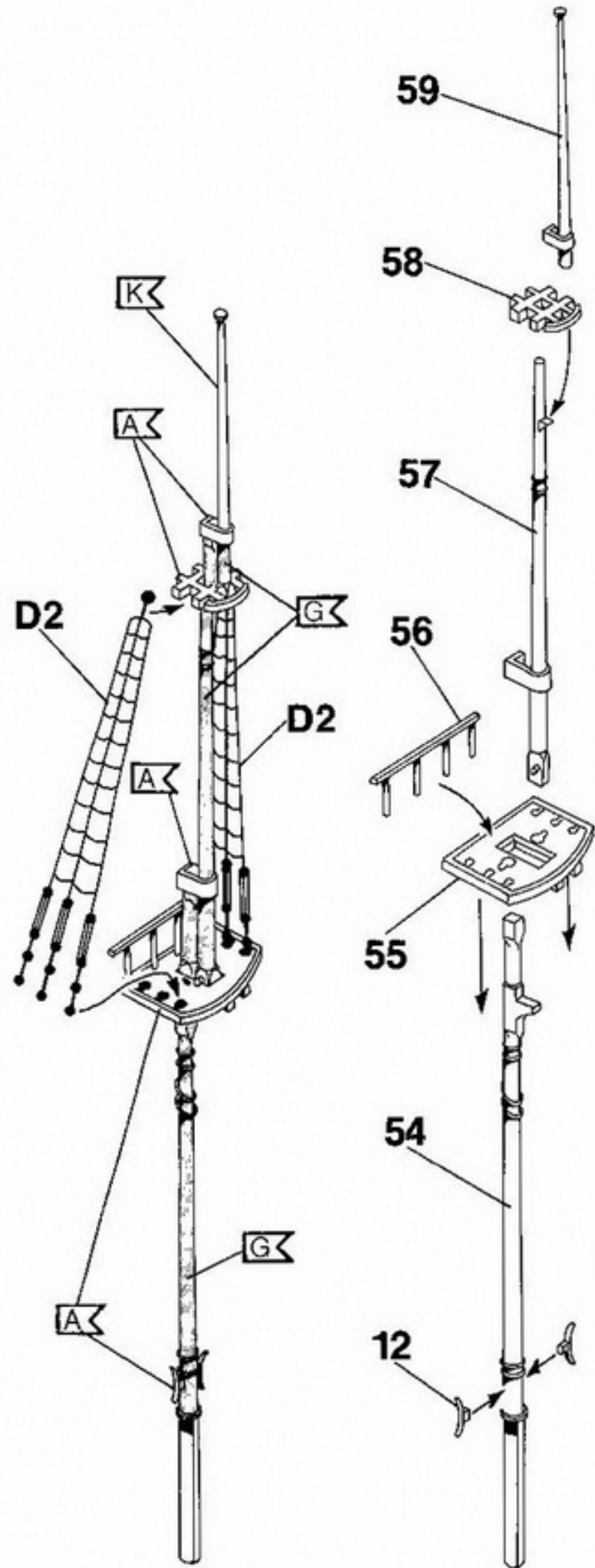

# 13



# 14

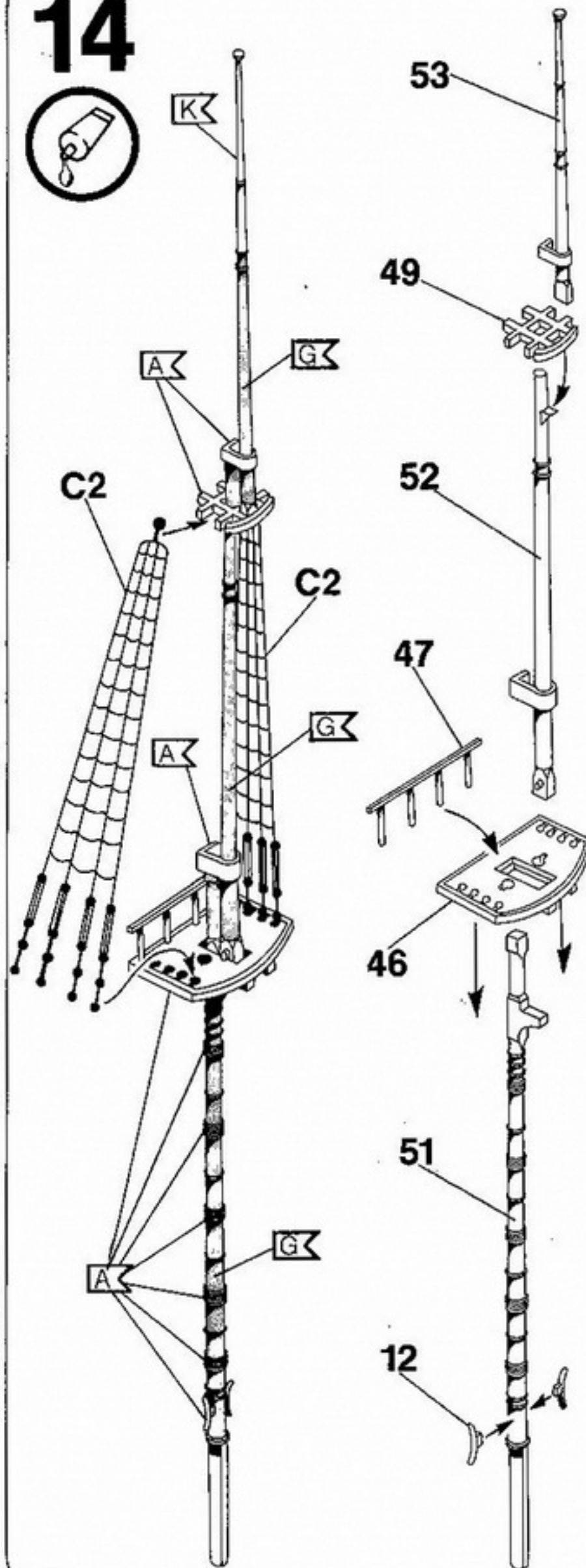

# 15

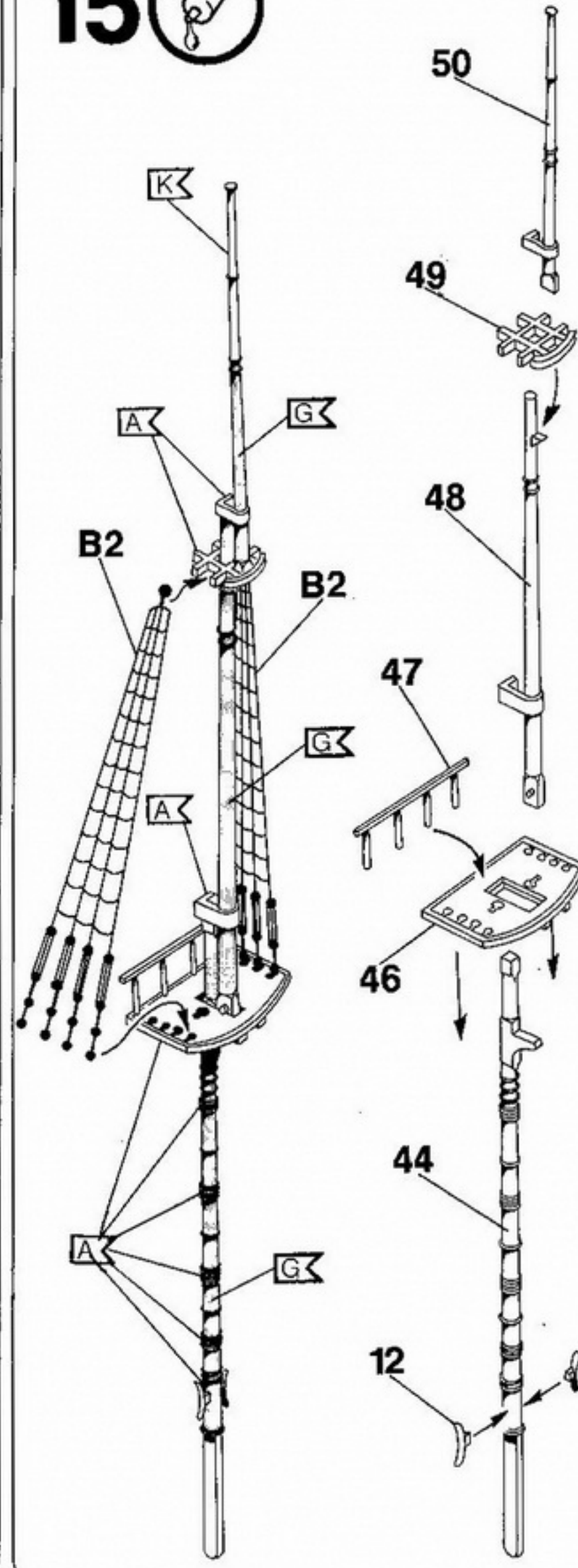



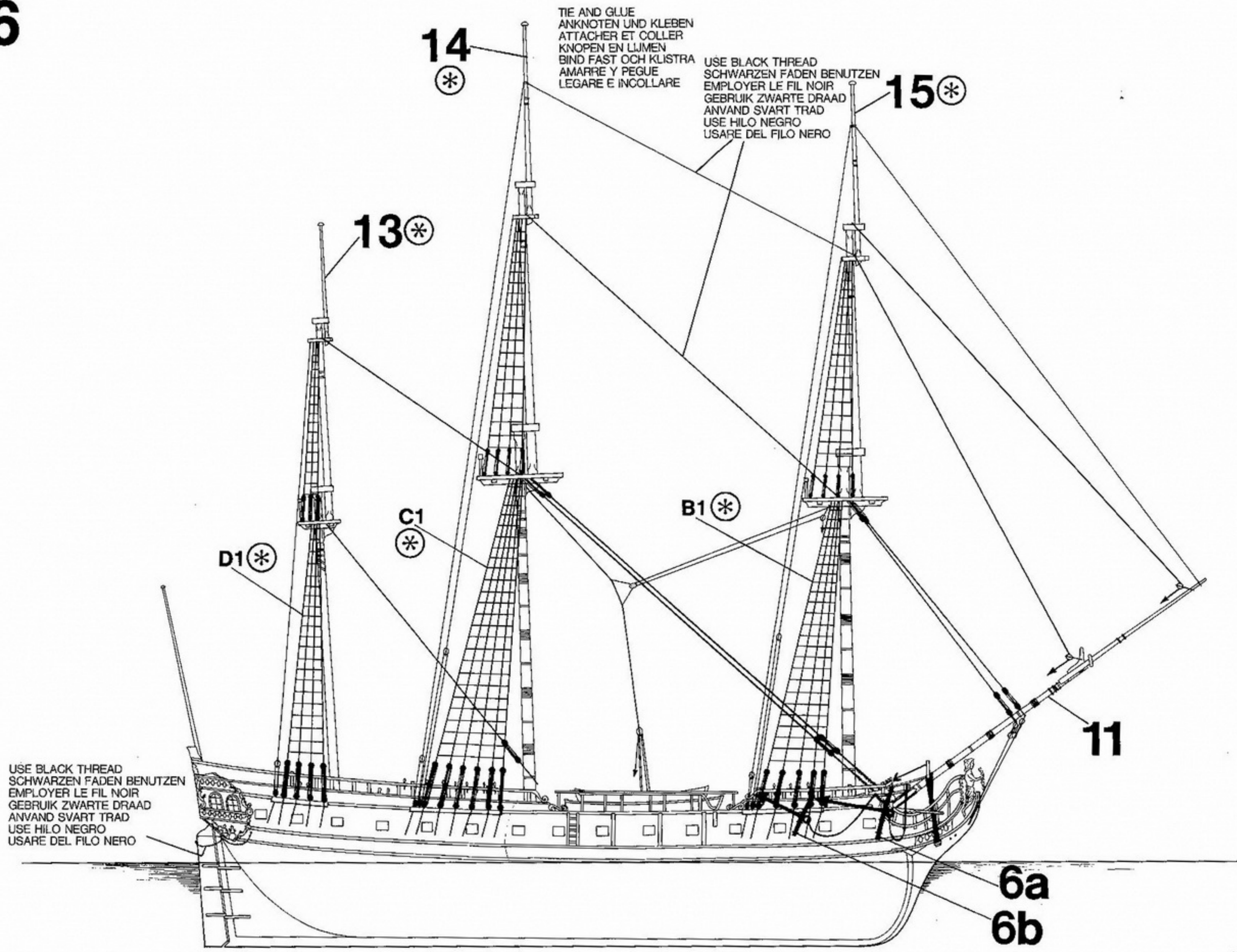

TIE AND GLUE  
 ANKNOTEN UND KLEBEN  
 ATTACHER ET COLLER  
 KNOPEN EN LIJMEN  
 BIND FAST OCH KLISTRA  
 AMARRE Y PEGUE  
 LEGARE E INCOLLARE

USE BLACK THREAD  
 SCHWARZEN FADEN BENUTZEN  
 EMPLOYER LE FIL NOIR  
 GEBRUIK ZWARTE DRAAD  
 ANVAND SVART TRAD  
 USE HILO NEGRO  
 USARE DEL FILO NERO

USE BLACK THREAD  
 SCHWARZEN FADEN BENUTZEN  
 EMPLOYER LE FIL NOIR  
 GEBRUIK ZWARTE DRAAD  
 ANVAND SVART TRAD  
 USE HILO NEGRO  
 USARE DEL FILO NERO

14\*

15\*

13\*

D1\*

C1\*

B1\*

11

6a  
6b

USE TAN THREAD  
 BRAUNEN FADEN BENUTZEN  
 EMPLOYER LE FIL BRUN  
 GEBUIK BRUINE DRAAD  
 ANVAND BEIGE TRAD  
 USE HILO COLOR MORENO

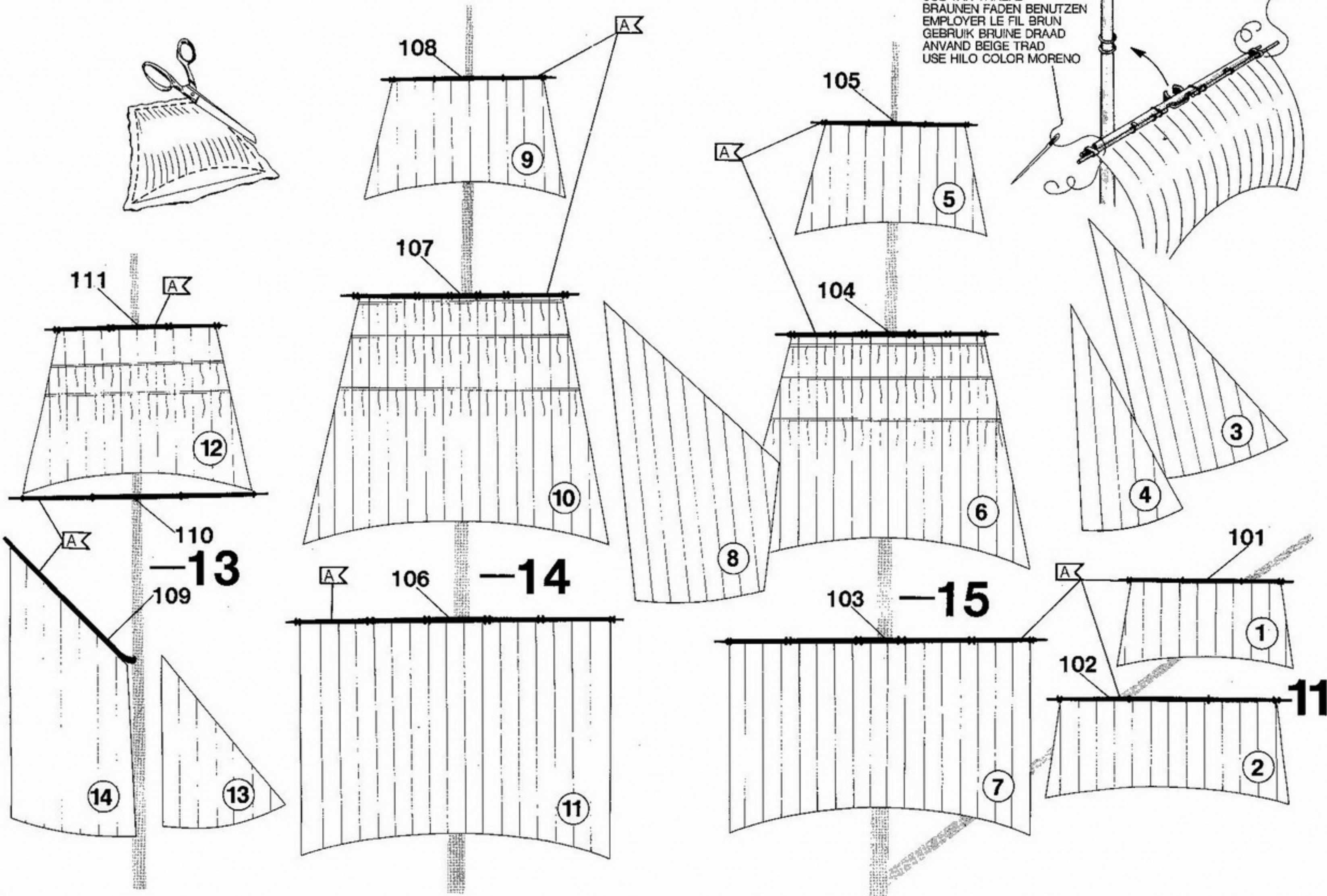
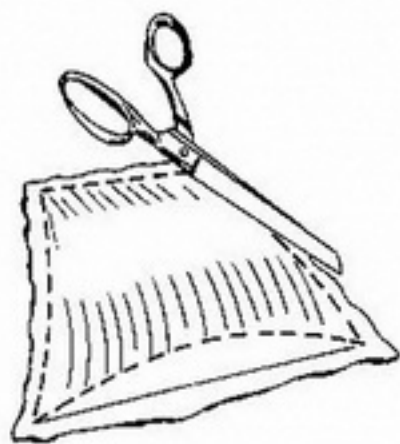

Pour toute pièce manquante, écrivez à REVELL PLASTICS GMBH, Postbus 2609 + 2620, département X, D-4980 Bünde, et cet élément vous sera aussitôt envoyé et ce, gratuitement. Il vous suffit dans ce cas de marquer d'une croix la pièce manquante sur la feuille d'instruction du modèle choisi. N'oubliez surtout pas d'écrire clairement votre nom et adresse.



USE TAN THREAD  
 BRAUNEN FADEN BENUTZEN  
 EMPLOYER LE FIL BRUN  
 GEBRUIK BRUINE DRAAD  
 ANVAND BEIGE TRAD  
 USE HILO COLOR MORENO

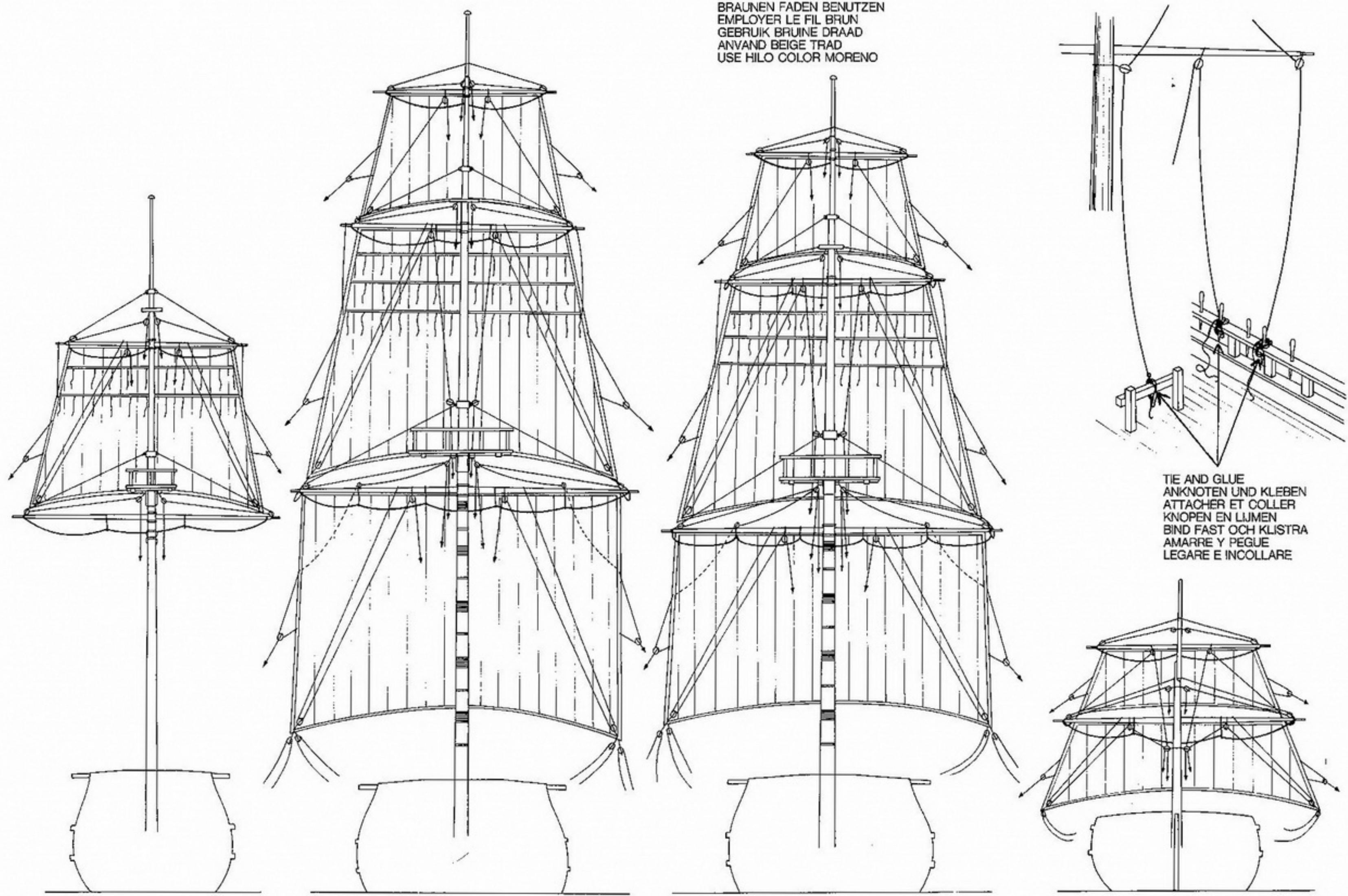

TIE AND GLUE  
 ANKNOTEN UND KLEBEN  
 ATTACHER ET COLLER  
 KNOPEN EN LIJMEN  
 BIND FAST OCH KLISTRA  
 AMARRE Y PEGUE  
 LEGARE E INCOLLARE

Zou het voorkomen, dat er een deel in de bouwdoos ontbreekt, kunt U schrijven naar REVELL PLASTICS GMBH, Postbus 2609 + 2620, Afdeling X, D-4980 Bunde. De bouwbeschrijving waarop het ontbrekende deel aangekruist is, bijsluiten, anders kunnen wij U dit onderdeel niet vergoeden. Vergeet vooral niet Uw naam en adres duidelijk te vermelden.



# 19

USE TAN THREAD  
BRAUNEN FADEN BENUTZEN  
EMPLOYER LE FIL BRUN  
GEBRUIK BRUINE DRAAD  
ANVAND BEIGE TRAD  
USE HILO COLOR MORENO

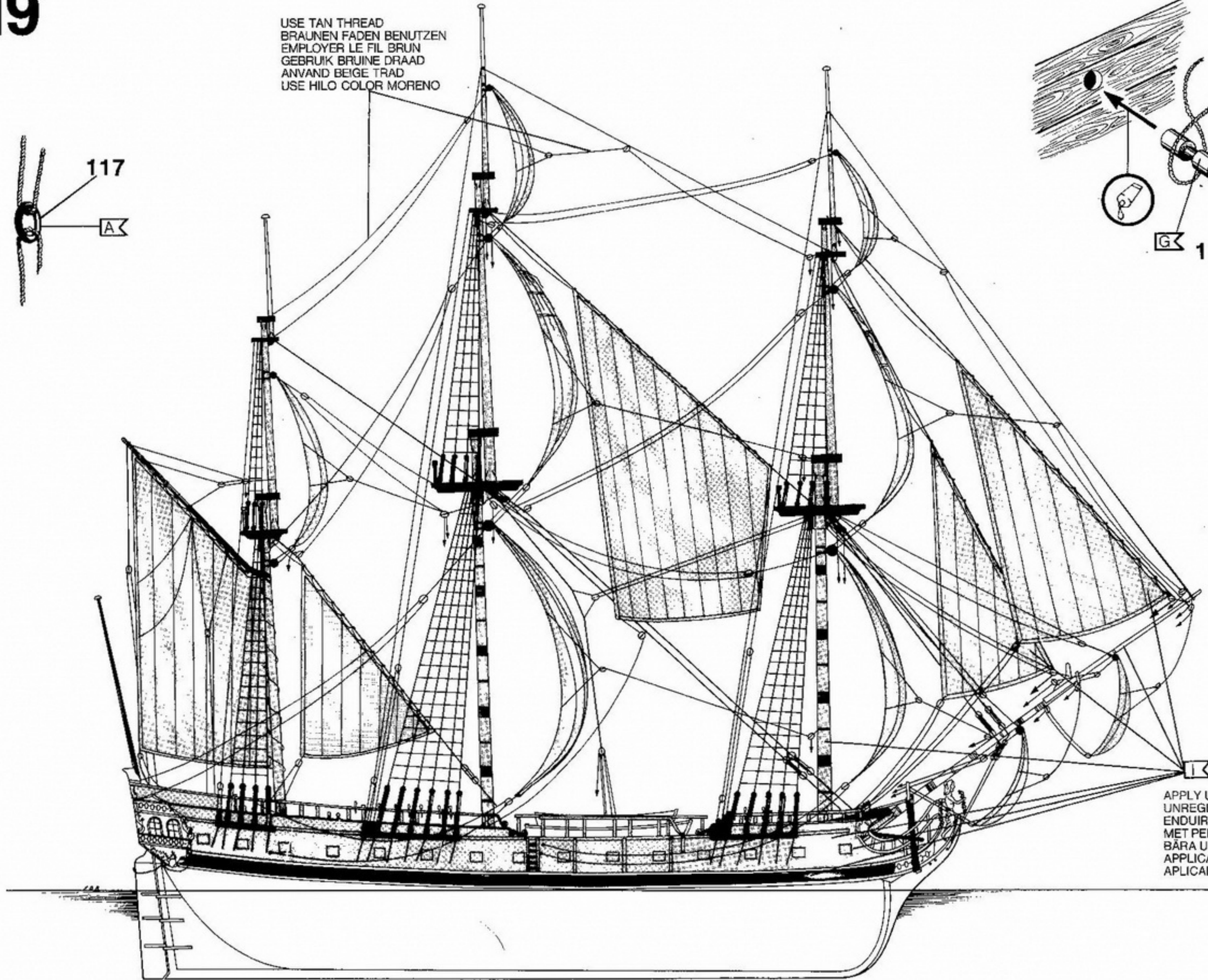
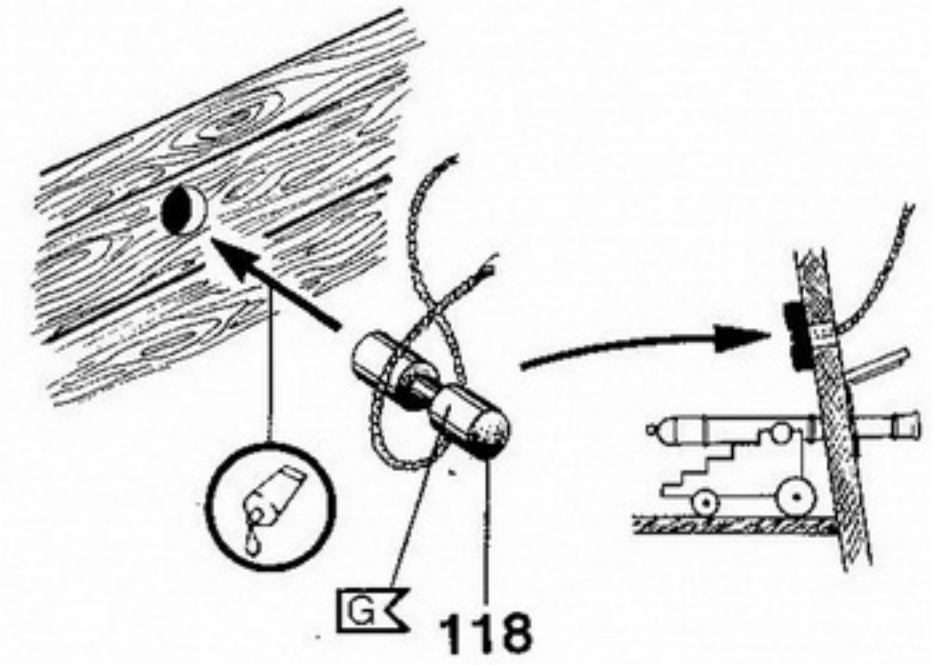
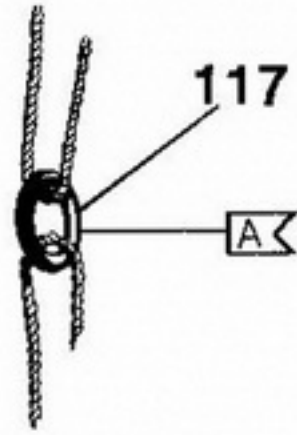

APPLY UNEVENLY WITH A BRUSH  
UNREGELMÄSSIG MIT EINEM PINSEL VERTEILEN  
ENDUIRE IRREGULIEREMENT D'UN PINCEAU  
MET PENSEEL ONREGELMATIG VERDELEN  
BÄRA UPP OREGELBUNDEN MED PENSEL  
APPLICARE IRREGOLARE CON UN PENELLO  
APLICAR IRREGULAR CON UN BROCHA

Sollte es einmal vorkommen, daß ein Teil im Bausatz fehlt, bitte an REVELL PLASTICS GMBH, Postfach 2609 + 2620, Abteilung X, 4980 Bünde, schreiben und die Bauanleitung, auf der das fehlende Teil angekreuzt ist, mitschicken, sonst können wir keinen Ersatz leisten.